



...eine starke Verbindung

DEKLARACJA WŁAŚCIWOŚCI UŻYTKOWYCH

DoP nr: **MKT-1.3-300_pl**

- ❖ **Niepowtarzalny kod identyfikacyjny typu wyrobu:** **Śruba do betonu BSZ2**
- ❖ **Zamierzone zastosowanie lub zastosowania:** Kotwa mechaniczna do stosowania w betonie, patrz załącznik B /Annex B
- ❖ **Producent:** MKT Metall-Kunststoff-Technik GmbH & Co.KG
Auf dem Immel 2
67685 Weilerbach
- ❖ **System lub systemy oceny i weryfikacji stałości właściwości użytkowych:** 1
- ❖ **Europejski dokument oceny:** **EAD 330232-01-0601**
Europejska ocena techniczna: **ETA-22/0551, 24.10.2022**
Jednostka ds. oceny technicznej: DIBt, Berlin
Jednostka lub jednostki notyfikowane: NB 2873 – Technische Universität Darmstadt

❖ **Deklarowane właściwości użytkowe:**

Zasadnicze charakterystyki	Właściwości użytkowe
Nośność i stateczność (BWR 1)	
Odporności charakterystyczne pod obciążeniem rozciągającym (efekty statyczne i quasi-statyczne)	Załącznik / Annex B2, C1
Odporności charakterystyczne na naprężenia poprzeczne (efekty statyczne i quasi-statyczne)	Załącznik / Annex C2
Wytrzymałość charakterystyczna i przemieszczenia dla kategorii wytrzymałości sejsmicznej C1	Załącznik / Annex C3
Przesunięcia (efekty statyczne i quasi-statyczne)	Załącznik / Annex C5
Trwałość	Załącznik / Annex B1
Bezpieczeństwo pożarowe (BWR 2)	
Zachowanie ogień	Klasa A1
Odporność ogniowa	Załącznik / Annex C4

Właściwości użytkowe określonego powyżej wyrobu są zgodne z zestawem deklarowanych właściwości użytkowych. Niniejsza deklaracja właściwości użytkowych wydana zostaje zgodnie z rozporządzeniem (EU) nr 305/2011 na wyłączną odpowiedzialność producenta określonego powyżej.

W imieniu producenta podpisał(-a):

Stefan Weustenhagen

(Kierownik)

Weilerbach, 24.10.2022

p.p.

Dipl.-Ing. Detlef Bigalke

(Kierownik Rozwoju Produktu)



Oryginał tej deklaracji właściwości użytkowych został sporządzony w języku niemieckim. W przypadku odchyłań w tłumaczeniu obowiązuje wersja niemiecka.

Specifications of Intended use

Concrete screw BSZ		BSZ2 6			BSZ2 8			BSZ2 10		
Nominal embedment depth	h_{nom} [mm]	$h_{nom1}^{1)}$	h_{nom2}	h_{nom3}	h_{nom1}	h_{nom2}	h_{nom3}	h_{nom1}	h_{nom2}	h_{nom3}
		35	45	55	45	55	65	55	75	85
Anchorage subject to	Static or quasi-static action	✓								
	Fire exposure	✓								
	Seismic action, performance category C1	Tension load: all anchor types		Shear load: anchor types B, S, SK, LK						
		2)	✓	✓	✓	2)	✓	✓	2)	✓
Base material	Cracked or uncracked concrete	✓								
	Compacted, reinforced or unreinforced concrete without fibres acc. to EN 206:2013+A1:2016	✓								
	Strength classes according to EN 206:2013+A1:2016, C20/25 to C50/60	✓								

1) Only for statically indeterminate non-structural systems (multiple use) according to EN 1992-4:2018, in dry internal conditions.

2) no performance assessed

Use conditions (Environmental conditions):

- Structures subject to dry internal conditions: all screw types
- For all other conditions corresponding to corrosion resistance classes CRC according to EN 1993-1-4:2006 +A1:2015:
 - stainless steel A4, according to Annex A3, Table A3: CRC III
 - high corrosion resistant steel HCR, according to Annex A3, Table A3: CRC V

Design:

- Anchorage are designed under the responsibility of an engineer experienced in anchorages and concrete work.
- Verifiable calculation notes and drawings are prepared taking account of the loads to be anchored. The position of the anchor is indicated on the design drawings (e.g. position of the anchor relative to reinforcement or to supports, etc.)
- Design method of anchorages according to EN 1992-4:2018 (if required in connection with EOTA Technical Report TR 055, version February 2018)

Installation:

- Making of drill hole by hammer drilling (all sizes) or vacuum drilling (BSZ 8 und BSZ 10). When using a vacuum drill bit no drill hole cleaning is required.
- Anchor installation carried out by appropriately qualified personal and under the responsibility of the person responsible for technical matters on site.
- After installation further turning of the anchor is not possible. The head of the anchor is supported on the fixture and is not damaged.
- The borehole may be filled with the Injection System VME plus.
- Adjustment according to Annex B4 (except for anchorages with filled borehole and anchorages with seismic action).

Concrete Screw BSZ2

Intended Use
Specifications

Annex B1

Table B1: Installation parameters

Screw size			BSZ2 6			BSZ2 8			BSZ2 10		
Nominal embedment depth	h_{nom}	[mm]	35 ¹⁾	45	55	45	55	65	55	75	85
Nominal drill bit diameter	d_0	[mm]	6			8			10		
Cutting diameter of drill bit	$d_{cut} \leq$	[mm]	6,40			8,45			10,45		
Depth of drill hole	$h_0 \geq$	[mm]	40	50	60	55	65	75	65	85	95
Diameter of clearance hole in the fixture	$d_f \leq$	[mm]	8			12			14		
Max. installation torque for screws with metric connection thread	$T_{inst} \leq$	[Nm]	10			20			40		
Tangential impact screw driver ²⁾	$T_{imp,max}$	[Nm]	160			300			450		

1) Only for statically indeterminate non-structural systems (multiple use) according to EN 1992-4:2018, in dry internal conditions.

2) Installation with tangential impact screw driver, with maximum torque $T_{imp,max}$ acc. to manufacturer's instructions is possible.

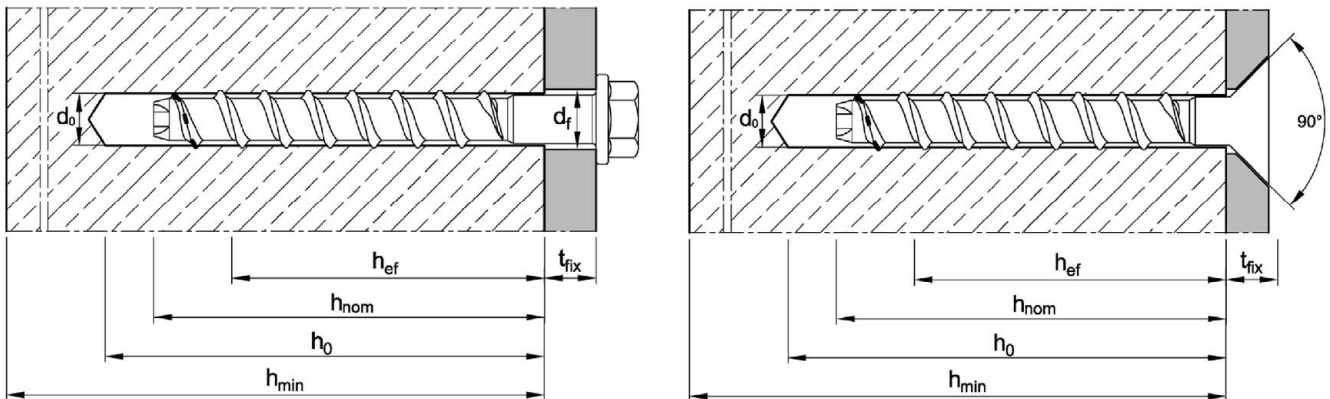

Table B2: Minimum thickness of member, minimum edge distance and minimum spacing

Screw size			BSZ2 6			BSZ2 8			BSZ2 10		
Nominal embedment depth	h_{nom}	[mm]	35 ¹⁾	45	55	45	55	65	55	75	85
Minimum thickness of member	h_{min}	[mm]	80	80	100	80	100	120	100	130	130
Minimum spacing	s_{min}	[mm]	35			35			40		
Minimum edge distance	c_{min}	[mm]	35			35			40		

1) Only for statically indeterminate non-structural systems (multiple use) according to EN 1992-4:2018, in dry internal conditions.

Concrete Screw BSZ2

Intended Use

Installation parameters / Minimum thickness of concrete member, minimum spacing and edge distance

Annex B2

Installation instructions

Drill hole preparation and cleaning		
1		<p>Drill hole perpendicular to concrete surface. Using a vacuum drill, continue with step 3.</p>
2		<p>Blow out dust or alternatively vacuum clean down to the bottom of the hole.</p>
Installation concrete screw		
3		<p>Screw in, e.g. with tangential impact screw driver or torque wrench.</p>
4		<p>After installation, the head of the anchor is supported on the fixture and must be undamaged.</p>
<p>For screw size BSZ2 6 with $h_{nom} = 35$ mm, installation only with impact screw drivers.</p>		

Concrete Screw BSZ2

Intended Use
Installation instructions

Annex B3

Installation instructions - Adjustment

1. Adjustment		
5		Screw may be untightened maximum 10 mm.
6		After adjustment, screw in the concrete screw with tangential impact screw driver or torque wrench.
7		After installation, the head of the anchor is supported on the fixture must be undamaged.
2. Adjustment		
8		Screw may be untightened maximum 10 mm.
9		After adjustment, screw in the concrete screw with tangential impact screw driver or torque wrench.
10		After installation, the head of the anchor is supported on the fixture and must be undamaged.
<p>Note: The concrete screw may be adjusted max. 2 times. The fastener must not be screwed back by more than 10 mm in each case. The relining carried out during adjustment must not exceed 10 mm in total. Nominal embedment depth h_{nom} must still be maintained after the adjustment.</p>		

Concrete Screw BSZ2

Intended Use
 Installation instructions - Adjustment

Annex B4

Installation instructions - filling of annular gap

Drill hole preparation and cleaning		
1		<p>Drill hole perpendicular to concrete surface. Using a vacuum drill, continue with step 3.</p>
2		<p>Blow out dust or alternatively vacuum clean down to the bottom of the hole.</p>
Installation concrete screw with filling washer		
3		<p>Fit the filling washer to the concrete screw or position at the attachment. The thickness of the filling washer must be taken into account with t_{fix}.</p>
4		<p>Screw in, e.g. with tangential impact screw driver or torque wrench.</p>
5		<p>Fill the annular gap between concrete screw and fixture with mortar (compressive strength $\geq 40 \text{ N/mm}^2$, e.g. Injection mortar VMH, VMZ or VMU plus). Use enclosed reducing adapter. Observe information on processing of the mortar! The annular gap is completely filled, when excess mortar seeps out.</p>
<p>For seismic loading, the application <u>with</u> and <u>without</u> filling of annular gap is permitted (Annex C3).</p>		

Concrete Screw BSZ2

Intended Use

Installation instructions - filling of annular gap

Annex B5

Table C1: Characteristic values for tension load under static or quasi-static action

Screw size				BSZ2 6			BSZ2 8			BSZ2 10		
Nominal embedment depth	h_{nom}	[mm]	35 ¹⁾	45	55	45	55	65	55	75	85	
Installation factor	γ_{inst}	[-]	1,0									
Steel failure												
Characteristic resistance	$N_{Rk,s}$	[kN]	14,0			27,0			45,0			
Partial factor ²⁾	$\gamma_{Ms,N}$	[-]	1,5									
Pull-out failure (concrete strength class C20/25)												
Characteristic resistance	cracked	$N_{Rk,p,cr}$	[kN]	2,5	1,5	3,0	3,0	5,5	8,0	6,0	13,0	17,0
	uncracked	$N_{Rk,p,ucr}$	[kN]	3,5	4,0	8,5	9,0	12,0	17,0	11,0	19,0	25,0
Exponent m for concrete increasing factor $\Psi_c = \left(\frac{f_{ck}}{20}\right)^m$												
Concrete strength class C25/30 to C50/60				$N_{Rk,p} = \psi/c \cdot N_{Rk,p} (C20/25)$								
Exponent m	cracked	m	[-]	0,41	0,35	0,50	0,50	0,50	0,50	0,50	0,39	0,39
	uncracked	m	[-]	0,35	0,50	0,38	0,50	0,50	0,30	0,50	0,50	0,50
Splitting failure												
Case 1	Characteristic resistance	$N^0_{Rk,sp}$	[kN]	$\min (N_{Rk,p} ; N^0_{Rk,c})$								
	Characteristic edge distance	$c_{cr,sp}$	[mm]	60	80	120	100	120	145	115	140	160
	Characteristic spacing	$s_{cr,sp}$	[mm]	120	160	240	200	240	290	230	280	320
Case 2	Characteristic resistance	$N^0_{Rk,sp}$	[kN]	3)	2,5	5,5	5,5	8,0	11,0	7,0	15,0	20,0
	Characteristic edge distance	$c_{cr,sp}$	[mm]	3)	58	84	64	82	98	80	114	130
	Characteristic spacing	$s_{cr,sp}$	[mm]	3)	116	168	128	164	196	160	224	260
Concrete cone failure												
Effective anchorage depth	h_{ef}	[mm]	25	34	42	32	41	49	40	57	65	
Factor	cracked	$k_{cr,N}$	[-]	7,7								
	uncracked	$k_{ucr,N}$	[-]	11,0								
Characteristic edge distance	$c_{cr,N}$	[mm]	$1,5 \cdot h_{ef}$									
Characteristic spacing	$s_{cr,N}$	[mm]	$3 \cdot h_{ef}$									

¹⁾ Only for statically indeterminate non-structural systems (multiple use) according to EN 1992-4:2018, in dry internal conditions.

²⁾ In absence of other national regulations.

³⁾ No performance assessed.

Concrete Screw BSZ2

Performances
Characteristic values for **tension load**

Annex C1

Table C2: Characteristic values for shear load under static or quasi static action

Screw size			BSZ2 6			BSZ2 8			BSZ2 10				
Nominal embedment depth	h_{nom}	[mm]	35 ¹⁾	45	55	45	55	65	55	75	85		
Installation factor	γ_{inst}	[-]	1,0										
Steel failure <u>without</u> lever arm													
Characteristic resistance	$V_{RK,s}^0$	[kN]	7,0			13,5			17,0		22,5		34,0
Partial factor ²⁾	$\gamma_{Ms,V}$	[-]	1,25										
Ductility factor	k_7	[-]	0,8										
Steel failure <u>with</u> lever arm													
Characteristic bending resistance	$M_{RK,s}^0$	[Nm]	10,9			26,0			56,0				
Concrete pry-out failure													
Pry-out factor	k_8	[-]	1,0	1,6		2,1	2,8		2,5				
Concrete edge failure													
Effective length of fastener in shear loading	$l_f = h_{nom}$	[mm]	35	45	55	45	55	65	55	75	85		
Outside diameter of anchor	d_{nom}	[mm]	6			8			10				

¹⁾ Only for statically indeterminate non-structural systems (multiple use) according to EN 1992-4:2018, in dry internal conditions.

²⁾ In absence of other national regulations

Concrete Screw BSZ2

Performances
Characteristic values for **shear load**

Annex C2

Table C3: Characteristic values for seismic loading, performance category C1

Screw size			BSZ2 6		BSZ2 8		BSZ2 10		
Nominal embedment depth	h_{nom}	[mm]	45	55	45	65	55	85	
Installation factor	γ_{inst}	[-]	1,0						
Tension load (all types)									
Steel failure									
Characteristic resistance	$N_{Rk,s,C1}$	[kN]	14,0		27,0		45,0		
Partial factor ¹⁾	$\gamma_{Ms,N}$	[-]	1,5						
Pull-out failure									
Characteristic resistance	$N_{Rk,p,C1}$	[kN]	1,5	3,0	3,0	8,5	6,0	17,0	
Concrete cone failure									
Effective anchorage depth	h_{ef}	[mm]	34	42	32	49	40	65	
Edge distance	$c_{cr,N}$	[mm]	1,5 · h_{ef}						
Spacing	$s_{cr,N}$	[mm]	3 · h_{ef}						
Shear load (Type : B, S, SK, LK)									
Steel failure without lever arm									
Characteristic resistance	Type B, S, LK	$V_{Rk,s,C1}$	[kN]	3,5	4,0	8,0	10,0	14,0	16,0
	Type SK	$V_{Rk,s,C1}$	[kN]	2,5	²⁾	4,5	7,0	14,0	10,0
Partial factor ¹⁾	$\gamma_{Ms,V}$	[-]	1,25						
with filling of annular gap	α_{gap}	[-]	1,0						
without filling of annular gap	α_{gap}	[-]	0,5						
Concrete pry-out failure									
Pry-out factor	k_8	[-]	1,6		2,1	2,8	2,5		
Concrete edge failure									
Effective length of anchor	$l_f = h_{nom}$	[mm]	45	55	45	65	55	85	
Outside diameter of anchor	d_{nom}	[mm]	6		8		10		

¹⁾ In absence of other national regulations

²⁾ No performance assessed

Concrete Screw BSZ2

Performances
Characteristic values for seismic loading

Annex C3

Table C4: Characteristic values under fire exposure

Screw size			BSZ2 6			BSZ2 8			BSZ2 10			
Nominal anchorage depth	h_{nom}	[mm]	35 ¹⁾	45	55	45	55	65	55	75	85	
Steel failure (tension and shear resistance)												
Characteristic resistance	R30	$N_{Rk,s,fi}$ = $V_{Rk,s,fi}$	[kN]	0,9			2,4			4,4		
	R60			0,8			1,7			3,3		
	R90			0,6			1,1			2,3		
	R120			0,4			0,7			1,7		
Steel failure <u>with</u> lever arm												
Characteristic bending resistance	R30	$M^0_{Rk,s,fi}$	[Nm]	0,7			2,4			5,9		
	R60			0,6			1,8			4,5		
	R90			0,5			1,2			3,0		
	R120			0,3			0,9			2,3		
Pull-out failure												
Characteristic resistance	R30-R90	$N_{Rk,p,fi}$	[kN]	0,6	0,4	0,8	0,8	1,4	2,0	1,5	3,3	4,3
	R120	$N_{Rk,p,fi}$	[kN]	0,5	0,3	0,6	0,6	1,1	1,6	1,2	2,6	3,4
Concrete cone failure												
Characteristic resistance	R30-R90	$N^0_{Rk,c,fi}$	[kN]	0,5	1,2	2,0	1,0	1,9	2,9	1,7	4,2	5,9
	R120	$N^0_{Rk,c,fi}$	[kN]	0,4	0,9	1,6	0,8	1,5	2,3	1,4	3,4	4,7
Edge distance	$c_{cr,fi}$	[mm]	2 · h_{ef}									
In case of fire attack from more than one side, the minimum edge distance shall be ≥ 300 mm												
Spacing	$s_{cr,fi}$	[mm]	4 · h_{ef}									
Concrete pry-out failure												
Pry-out factor	k_8	[-]	1,0	1,6	2,1	2,8	2,5					
The anchorage depth has to be increased for wet concrete by at least 30 mm compared to the given values.												

¹⁾ Only for statically indeterminate non-structural systems (multiple use) according to EN 1992-4:2018, in dry internal conditions.

Concrete Screw BSZ2

Performances
Characteristic values under **fire exposure**

Annex C4

Table C5: Displacements under static or quasi-static loads

Screw size			BSZ2 6		BSZ2 8			BSZ2 10			
Nominal embedment depth	h_{nom}	[mm]	45	55	45	55	65	55	75	85	
Tension load											
cracked concrete	Tension load	N	[kN]	0,72	1,45	1,63	2,74	4,06	3,04	6,22	8,46
	Displacement	δ_{N0}	[mm]	0,19	0,27	0,27	0,53	0,45	0,26	0,58	0,61
		$\delta_{N\infty}$	[mm]	0,55	0,84	0,49	0,66	0,61	0,69	0,92	1,10
uncracked concrete	Tension load	N	[kN]	2,11	4,07	4,24	5,97	8,03	5,42	9,17	12,28
	Displacement	δ_{N0}	[mm]	0,42	0,43	0,33	0,49	0,58	0,84	0,62	0,79
		$\delta_{N\infty}$	[mm]	0,42	0,43	0,58			0,79		
Shear load											
Shear load	V	[kN]	3,3			8,6			16,2		
Displacement	δ_{V0}	[mm]	1,55			2,7			2,7		
	$\delta_{V\infty}$	[mm]	3,1			4,1			4,3		

Concrete Screw BSZ2

Performances
Displacements

Annex C5