

SUORITUSTASOILMOITUS

DoP Nro: **MKT-711 - fi**

- ✧ **Tuotetyypin yksilöllinen tunniste:** **Bolt ankkuri BL / BS**
- ✧ **Aiottu käyttötarkoitus (aiotut käyttötarkoitukset):** Mekaaninen bolt ankkuri betonissa käytettäväksi, katso liite / Annex B
- ✧ **Valmistaja:** MKT Metall-Kunststoff-Technik GmbH & Co.KG
Auf dem Immel 2
67685 Weilerbach
- ✧ **Rakennustuotteen suoritusasteen pysyvyyden arviointi- ja varmennusjärjestelmä(t)::** 1
- ✧ **Eurooppalainen arviointiasiakirja:** **EAD 330232-00-0601**
Eurooppalainen tekninen arviointi: **ETA-16/0204, 19.09.2019**
Teknisestä arvioinnista vastaava laitos: DIBt, Berlin
Ilmoitettu laitos/ilmoitetut laitokset: NB 1343 – MPA, Darmstadt

✧ **Ilmoitettu suoritusaste/ilmoitetut suoritusasteet:**

Olennaiset ominaisuudet	Suoritusaste
Mekaaninen lujuus ja vakaus (BWR 1)	
Ominaisresistanssit vetolujuudessa (staattiset ja lähes staattiset vaikutukset)	Liite / Annex C1
Ominaisresistanssit poikittaisessa rasituksessa (staattiset ja lähes staattiset vaikutukset)	Liite / Annex C1
Ominaisvastus ja seismiselle suorituskykyluokalle C1 + C2	Liite / Annex C2, C3, C4, C7
Vuorossa (staattiset ja lähes staattiset vaikutukset)	Liite / Annex C6
Kierrätettävyys	Liite / Annex B1
Paloturvallisuus (BWR 2)	
Palokäyttäytyminen	Luokka A1
Palonkestävyys	Liite / Annex C5

Edellä yksilöidyn tuotteen suoritusaste on ilmoitettujen suoritusasteiden joukon mukainen. Tämä suoritusasteilmoitus on asetuksen (EU) N:o 305/2011 mukaisesti annettu edellä ilmoitetun valmistajan yksinomaisella vastuulla.

Valmistajan puolesta allekirjoittanut:



Stefan Weustenhagen
(Toimitusjohtaja)
Weilerbach, 19.09.2019

p.p.

Dipl.-Ing. Detlef Bigalke
(Tuotekehityksen johtaja)



Tämän suoritusasteilmoituksen alkuperäinen teksti on kirjoitettu saksaksi. Jos käännökset poikkeavat toisistaan, saksankielinen versio on pätevä.

Specifications of Intended use

Concrete screw BSZ		BSZ 6		BSZ 8			BSZ 10			BSZ 12			BSZ 14		
Nominal anchorage depth h_{nom} [mm]		40	55	45	55	65	55	75	85	65	85	100	75	100	115
Anchorage subject to	Static or quasi-static loading	✓		✓			✓			✓			✓		
	Fire exposure	✓		✓			✓			✓			✓		
	Seismic action C1	-		-		✓	-		✓	-		✓	-		✓
	Seismic action C2 (concrete screw BSZ, zinc plated)	-		-		✓	-		✓	-		✓	-		✓
Base material	Cracked or uncracked concrete	✓		✓			✓			✓			✓		
	Reinforced or unreinforced concrete (without fibres) acc. to EN 206:2013	✓		✓			✓			✓			✓		
	Strength classes according to EN 206:2013: C20/25 to C50/60	✓		✓			✓			✓			✓		

Use conditions (Environmental conditions):

- Structures subject to dry internal conditions (zinc plated steel, stainless steel or high corrosion resistant steel)
- Structures subject to external atmospheric exposure including industrial and marine environment or exposure to permanently damp internal condition, if no particular aggressive conditions exist (stainless steel or high corrosion resistant steel)
- Structures subject to external atmospheric exposure and to permanently damp internal condition, if other particular aggressive conditions exist (high corrosion resistant steel)

Note: Particular aggressive conditions are e.g. permanent, alternation immersion in seawater or the splash zone of seawater, chloride atmosphere of indoor pools or atmosphere with extreme chemical pollution (e.g. in desulphurization plants or road tunnels where de-icing materials are used)

Design:

- Anchorage are designed under the responsibility of an engineer experienced in anchorages and concrete work.
- Verifiable calculation notes and drawings are prepared taking account of the loads to be anchored. The position of the anchor is indicated on the design drawings (e.g. position of the anchor relative to reinforcement or to supports, etc.)
- Design method of anchorages under static or quasi-static load according to EN 1992-4:2018 and EOTA Technical Report TR 055.

The design method of anchorages under shear load according to EN 1992-4:2018, section 6.2.2. also applies for the specified diameter d_f of the clearance hole in the fixture in Annex B2, Table B1

Installation:

- Making of drill hole by hammer drilling (all sizes) or vacuum drill bit (BSZ 8 – BSZ 14). When using a vacuum drill bit no drill hole cleaning is required.
- Anchor installation carried out by appropriately qualified personal and under the responsibility of the person responsible for technical matters on site.
- After installation further turning of the anchor is not possible. The head of the anchor is supported on the fixture and is not damaged.
- The borehole may be filled with injection mortar with a compressive strength of 40 N/mm² (e.g. MKT Injection mortar VMZ, VMH or VMU plus).
- Adjustment according to Annex B4: for concrete bolts BSZ 8 to BSZ 14, all anchorage depths for static or quasi-static loads.

Concrete Screw BSZ

Intended use
Specifications

Annex B1

Table B1: Installation parameters

Anchor size		BSZ 6		BSZ 8			BSZ 10			BSZ 12			BSZ 14		
Nominal embedment depth	h_{nom} [mm]	40	55	45	55	65	55	75	85	65	85	100	75	100	115
Nominal drill bit diameter	d_0 [mm]	6		8			10			12			14		
Cutting diameter of drill bit	$d_{cut} \leq$ [mm]	6,40		8,45			10,45			12,50			14,50		
Effective anchorage depth	h_{ef} [mm]	31	44	35	43	52	43	60	68	50	67	80	58	79	92
Depth of drill hole	$h_1 \geq$ [mm]	45	60	55	65	75	65	85	95	75	95	110	85	110	125
Diameter of clearance hole in the fixture	$d_f \leq$ [mm]	8		12			14			16			18		
Max. installation torque for screws with metric connection thread	$T_{inst} \leq$ [Nm]	10		20			40			60			80		
Tangential impact screw driver ¹⁾	$T_{imp,max}$ [Nm]	160		300			400			650			650		

¹⁾ Installation with tangential impact screw driver, with maximum power output $T_{imp,max}$ acc. to manufacturers instructions is possible

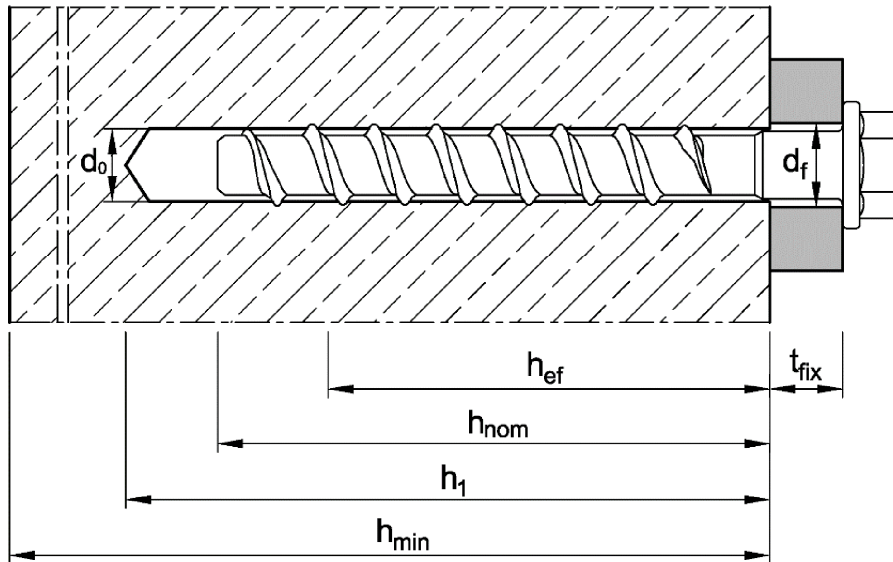

Table B2: Minimum thickness of member, minimum edge distance and minimum spacing

Anchor size		BSZ 6		BSZ 8			BSZ 10			BSZ 12			BSZ 14			
Nominal embedment depth	h_{nom} [mm]	40	55	45	55	65	55	75	85	65	85	100	75	100	115	
Minimum thickness of member	h_{min} [mm]	100		100		120	100		130	120		130	150	130	150	170
Minimum spacing	s_{min} [mm]	40		40	50		50			50		70	50	70		
Minimum edge distance	c_{min} [mm]	40		40	50		50			50		70	50	70		

Concrete Screw BSZ

Intended use

Installation parameters / Minimum thickness of concrete member, minimum spacing and edge distance

Annex B2

Installation instructions

Drill hole preparation and cleaning

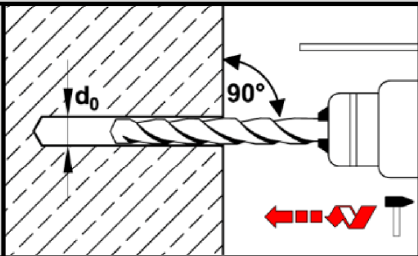
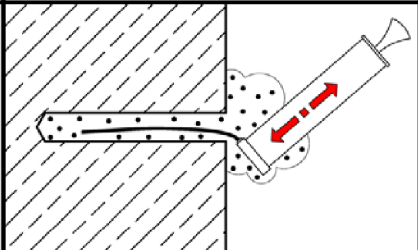
1		Drill hole perpendicular to concrete surface. Using a suction drill, continue with step 3.
2		Blow out dust or alternatively vacuum clean down to the bottom of the hole.

Installation concrete screw

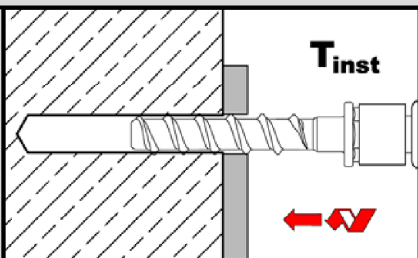
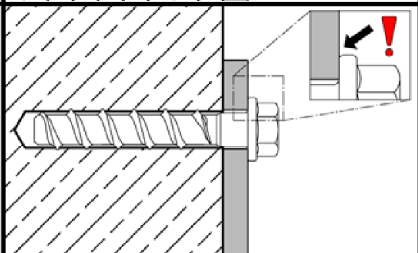
3		Screw in, e.g. with tangential impact screw driver or torque wrench.
4		After installation, the head of the anchor is supported on the fixture and must be undamaged.

Concrete Screw BSZ

Intended use
Installation instructions

Annex B3

Installation instructions - filling of annular gap

Drill hole preparation and cleaning

1		<p>Drill hole perpendicular to concrete surface. Using a suction drill, continue with step 3.</p>
2		<p>Blow out dust or alternatively vacuum clean down to the bottom of the hole.</p>

Installation concrete screw with filling washer

3		<p>Fit the filling washer to the concrete screw. The thickness of the filling washer must be taken into account with t_{fix}.</p>
4		<p>Screw in, e.g. with tangential impact screw driver or torque wrench.</p>
6		<p>Fill the annular gap between concrete screw and fixture with mortar (compressive strength $\geq 40 \text{ N/mm}^2$, e.g. Injection mortar VMH, VMZ or VMU plus). Use enclosed reducing adapter. Observe the processing information of the mortar! The annular gap is completely filled, when excess mortar seeps out.</p>

For seismic loading, the application with and without filling of annular gap is permitted (Annex C3-C4).

Filling washer and reducing adapter for filling the annular gap between concrete screw and fixture

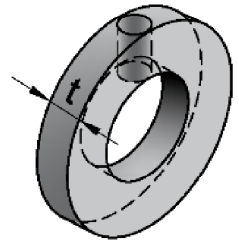

thickness of filling washer
 $t = 5 \text{ mm}$

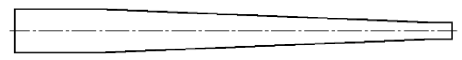

Concrete Screw BSZ

Intended use
Installation instructions with filling of annular gap

Annex B4

Installation instructions - Adjustment

Drill hole preparation and cleaning see Annex B3, Picture 1 and 2

1. Adjustment

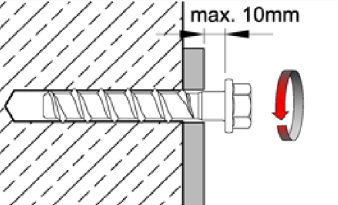
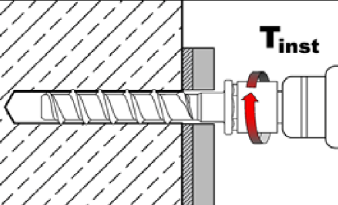
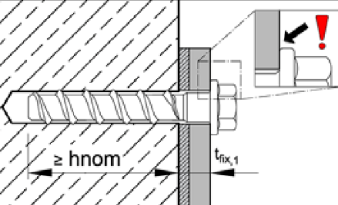
3		Screw may be untightened maximum 10mm.
4		After adjustment, screw in the concrete screw with with tangential impact screw driver or torque wrench.
5		After installation, the head of the anchor is supported on the fixture must be undamaged.

2. Adjustment

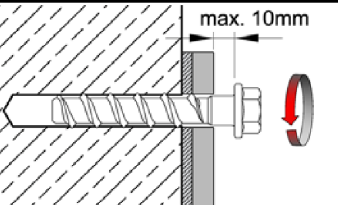
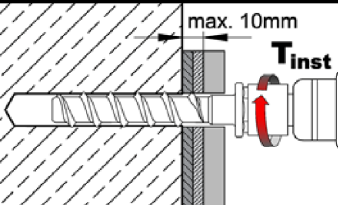
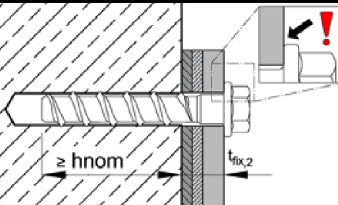
6		Screw may be untightened maximum 10mm.
7		After adjustment, screw in the concrete screw with with tangential impact screw driver or torque wrench.
8		After installation, the head of the anchor is supported on the fixture and must be undamaged.

- adjustment is only permitted for fixings with concrete screws size BSZ 8 - BSZ 14 under static or quasi-static load.
- the fastener may be adjusted max. 2x. The fastener must not be screwed back by more than 10mm in each case. The relining carried out during adjustment must not exceed 10 mm in total. Nominal embedment depth h_{nom} must still be maintained after the adjustment.

Concrete Screw BSZ

Intended use

Installation instructions - Adjustment

Annex B5

Table C1: Characteristic values for static or quasi-static loads

Anchor size		BSZ 6		BSZ 8			BSZ 10			BSZ 12			BSZ 14					
Nominal embedment depth	h_{nom} [mm]	40	55	45	55	65	55	75	85	65	85	100	75	100	115			
Installation factor	γ_{inst} [-]	1,0																
Tension load																		
Steel failure																		
Characteristic resistance	$N_{RK,s}$ [kN]	14		27			45			67			94					
Partial factor	$\gamma_{Ms,N}$ [-]	1,5																
Pull-out																		
Characteristic resistance in concrete C20/25	cracked	$N_{RK,p}$ [kN]	2,0	4,0	5,0	9,0	12	9,0	$\geq N_{RK,c}^0$	12	$\geq N_{RK,c}^0$		$\geq N_{RK,c}^0$					
	uncracked	$N_{RK,p}$ [kN]	4,0	9,0	7,5	12	16	12	20	26						16		
Increasing factor for $N_{RK,p}$	Ψ_C [-]	$\left(\frac{f_{ck}}{20}\right)^{0,5}$																
Concrete cone failure																		
Effective anchorage depth	h_{ef} [mm]	31	44	35	43	52	43	60	68	50	67	80	58	79	92			
Spacing	$s_{cr,N}$ [mm]	$3 h_{ef}$																
Edge distance	$c_{cr,N}$ [mm]	$1,5 h_{ef}$																
Factor k_1	cracked	$k_{cr,N}$ [-]	7,7															
	uncracked	$k_{ucr,N}$ [-]	11,0															
Splitting																		
Spacing	$s_{cr,sp}$ [mm]	120	160	120	140	150	140	180	210	150	210	240	180	240	280			
Edge distance	$c_{cr,sp}$ [mm]	60	80	60	70	75	70	90	105	75	105	120	90	120	140			
Shear load																		
Steel failure <u>without</u> lever arm																		
Characteristic resistance	$V_{RK,s}^0$ [kN]	7,0		13,5		17,0		22,5		34,0		33,5		42,0		56,0		
Partial factor	$\gamma_{Ms,V}$ [-]	1,25																
Ductility factor	k_7 [-]	0,8																
Steel failure <u>with</u> lever arm																		
Characteristic bending resistance	$M_{RK,s}^0$ [Nm]	10,9		26			56			113			185					
Concrete pry-out failure																		
Pry-out factor	k_8 [-]	1,0		1,0			1,0		2,0		1,0		2,0		1,0		2,0	
Concrete edge failure																		
Effective length of anchor	$l_f = h_{ef}$ [mm]	31	44	35	43	52	43	60	68	50	67	80	58	79	92			
Outside diameter of anchor	d_{nom} [mm]	6		8			10			12			14					

Concrete Screw BSZ
Performance

 Characteristic values for **static** or **quasi-static** loads

Annex C1

Table C2: Characteristic resistance for **seismic loading**, performance category **C1**

Anchor size			BSZ 8	BSZ 10	BSZ 12	BSZ 14
Nominal embedment depth	h_{nom}	[mm]	65	85	100	115
Installation factor	γ_{inst}	[-]	1,0			
Tension load						
Steel failure						
Characteristic resistance	$N_{Rk,s,eq}$	[kN]	27	45	67	94
Partial factor	γ_{Ms}	[-]	1,5			
Pull-out						
Characteristic resistance	$N_{Rk,p,eq}$	[kN]	12	$\geq N_{Rk,c}^0$		
Concrete cone failure						
Effective anchorage depth	h_{ef}	[mm]	52	68	80	92
Spacing	$s_{cr,N}$	[mm]	3 h_{ef}			
Edge distance	$c_{cr,N}$	[mm]	1,5 h_{ef}			
Shear load						
Steel failure <u>without</u> lever arm						
Characteristic resistance	$V_{Rk,s,eq}$	[kN]	8,5	15,3	21,0	22,4
Partial factor	γ_{Ms}	[-]	1,25			
Concrete pry-out failure						
Pry-out factor	k_8	[-]	1,0	2,0		
Concrete edge failure						
Effective length of anchor	$l_f = h_{ef}$	[mm]	52	68	80	92
Outside diameter of anchor	d_{nom}	[mm]	8	10	12	14
Factor for <u>with</u> filling of annular gap	α_{gap}	[-]	1,0			
annular gap <u>without</u> filling of annular gap	α_{gap}	[-]	0,5			

Concrete Screw BSZ

Performance

Characteristic resistance for **seismic loading**, performance category **C1**

Annex C2

Table C3: Characteristic resistance for **seismic loading**, performance category **C2**, **with filling of annular gap**, concrete screw BSZ zinc plated

Anchor size		BSZ 8	BSZ 10	BSZ 12	BSZ 14
Nominal embedment depth	h_{nom} [mm]	65	85	100	115
Installation factor	γ_{inst} [-]	1,0			
Tension load					
Steel failure					
Characteristic resistance	$N_{Rk,s,eq}$ [kN]	27	45	67	94
Partial factor	γ_{Ms} [-]	1,5			
Pull-out					
Characteristic resistance	$N_{Rk,p,eq}$ [kN]	2,4	5,4	7,1	10,5
Concrete cone failure					
Effective anchorage depth	h_{ef} [mm]	52	68	80	92
Spacing	$s_{cr,N}$ [mm]	3 h_{ef}			
Edge distance	$c_{cr,N}$ [mm]	1,5 h_{ef}			
Shear load					
Steel failure without lever arm					
Characteristic resistance	$V_{Rk,s,eq}$ [kN]	9,9	18,5	31,6	40,7
Partial factor	γ_{Ms} [-]	1,25			
Concrete pry-out failure					
Pry-out factor	k_8 [-]	2,0			
Concrete edge failure					
Effective length of anchor	$l_f = h_{ef}$ [mm]	52	68	80	92
Outside diameter of anchor	d_{nom} [mm]	8	10	12	14
Factor for annular gap with filling of annular gap	α_{gap} [-]	1,0			

Concrete Screw BSZ

Performance
 Characteristic resistance for **seismic loading**, performance category **C2**
with filling of annular gap

Annex C3

Table C4: Characteristic resistance for **seismic loading**, performance category **C2**, **without filling of annular gap**, concrete screw BSZ zinc plated

Anchor size			BSZ 8	BSZ 10	BSZ 12	BSZ 14	
Nominal embedment depth	h_{nom}	[mm]	65	85	100	115	
Installation factor	γ_{inst}	[-]	1,0				
Tension loads							
hexagon drive	Steel failure						
	Characteristic resistance	$N_{Rk,s,eq}$	[kN]	27	45	67	94
	Partial factor	γ_{Ms}	[-]	1,5			
	Pull-out						
	Characteristic resistance	$N_{Rk,p,eq}$	[kN]	2,4	5,4	7,1	10,5
countersunk version	Steel failure						
	Characteristic resistance	$N_{Rk,s,eq}$	[kN]	27	45	-	-
	Partial factor	γ_{Ms}	[-]	1,5		-	-
	Pull-out						
	Characteristic resistance	$N_{Rk,p,eq}$	[kN]	2,4	5,4	-	-
Concrete cone failure							
Effective anchorage depth	h_{ef}	[mm]	52	68	80	92	
Spacing	$s_{cr,N}$	[mm]	3 h_{ef}				
Edge distance	$c_{cr,N}$	[mm]	1,5 h_{ef}				
Shear loads							
Steel failure <u>without</u> lever arm							
hexagon drive	Characteristic resistance	$V_{Rk,s,eq}$	[kN]	10,3	21,9	24,4	23,3
	Partial factor	γ_{Ms}	[-]	1,25			
counter- sunk version	Characteristic resistance	$V_{Rk,s,eq}$	[kN]	3,6	13,7	-	-
	Partial factor	γ_{Ms}	[-]	1,25		-	-
Concrete pry-out failure							
Pry-out factor	k_8	[-]	2,0				
Concrete edge failure							
Effective length of anchor	$l_f = h_{ef}$	[mm]	52	68	80	92	
Outside diameter of anchor	d_{nom}	[mm]	8	10	12	14	
Factor for annular gap without filling of annular gap	α_{gap}	[-]	0,5				

Concrete Screw BSZ

Performance
 Characteristic resistance for **seismic loading**, performance category **C2**
without filling of annular gap

Annex C4

Table C5: Characteristic values of resistance under fire exposure

Anchor size			BSZ 6		BSZ 8			BSZ 10			BSZ 12			BSZ 14		
Nominal anchorage depth	h_{nom}	[mm]	40	55	45	55	65	55	75	85	65	85	100	75	100	115
Steel failure (tension and shear resistance)																
Characteristic resistance	R30	$N_{RK,s,fi}$ = $V_{RK,s,fi}$	[kN]	0,9		2,4		4,4		7,3		10,3				
	R60			0,8		1,7		3,3		5,8		8,2				
	R90			0,6		1,1		2,3		4,2		5,9				
	R120			0,4		0,7		1,7		3,4		4,8				
Steel failure <u>with</u> lever arm																
Characteristic bending resistance	R30	$M^0_{RK,s,fi}$	[Nm]	0,7		2,4		5,9		12,3		20,4				
	R60			0,6		1,8		4,5		9,7		15,9				
	R90			0,5		1,2		3,0		7,0		11,6				
	R120			0,3		0,9		2,3		5,7		9,4				
Edge distance	$c_{cr,fi}$	[mm]	$2 h_{ef}$													
In case of fire attack from more than one side, the minimum edge distance shall be ≥ 300 mm																
Spacing	$s_{cr,fi}$	[mm]	$4 h_{ef}$													
The characteristic resistance for pull-out, concrete cone failure, concrete pry-out and concrete edge failure shall be calculated according to EN 1992-4:2018.																
The anchorage depth has to be increased for wet concrete by at least 30 mm compared to the given values																

Concrete Screw BSZ

Performance
Characteristic values of resistance under **fire exposure**

Annex C5

Table C6: Displacements under static or quasi-static loads

Anchor size			BSZ 6		BSZ 8			BSZ 10			BSZ 12			BSZ 14			
Nominal embedment depth	h_{nom}	[mm]	40	55	45	55	65	55	75	85	65	85	100	75	100	115	
Tension load																	
cracked concrete	Tension load	N [kN]	0,95	1,9	2,4	4,3	5,7	4,3	7,9	9,6	5,7	9,4	12,3	7,6	12,0	15,1	
	Displacement	δ_{N0}	[mm]	0,3	0,6	0,6	0,7	0,8	0,6	0,5	0,9	0,9	0,5	1,0	0,5	0,8	0,7
		$\delta_{N\infty}$	[mm]	0,4	0,4	0,6	1,0	0,9	0,4	1,2	1,2	1,0	1,2	1,2	0,9	1,2	1,0
uncracked concrete	Tension load	N [kN]	1,9	4,3	3,6	5,7	7,6	5,7	9,5	11,9	7,6	13,2	17,2	10,6	16,9	21,2	
	Displacement	δ_{N0}	[mm]	0,4	0,6	0,7	0,9	0,5	0,7	1,1	1,0	1,0	1,1	1,2	0,9	1,2	0,8
		$\delta_{N\infty}$	[mm]	0,4	0,4	0,6	1,0	0,9	0,4	1,2	1,2	1,0	1,2	1,2	0,9	1,2	1,0
Shear load																	
	Shear load	V [kN]	3,3		8,6			16,2			20,0			30,5			
Displacement	δ_{V0}	[mm]	1,55		2,7			2,7			4,0			3,1			
	$\delta_{V\infty}$	[mm]	3,1		4,1			4,3			6,0			4,7			

Concrete Screw BSZ

Performance
Displacements under static or quasi-static loads

Annex C6

Table C7: Displacements under **seismic loading**, performance category **C2**
with filling of annular gap, concrete screw BSZ zinc plated

Anchor size			BSZ 8	BSZ 10	BSZ 12	BSZ 14
Nominal embedment depth	h_{nom}	[mm]	65	85	100	115
Tension load						
Displacement DLS	$\delta_{N,eq(DLS)}$	[mm]	0,66	0,32	0,57	1,16
Displacement ULS	$\delta_{N,eq(ULS)}$	[mm]	1,74	1,36	2,36	4,39
Shear load						
Displacement DLS	$\delta_{V,eq(DLS)}$	[mm]	1,68	2,91	1,88	2,42
Displacement ULS	$\delta_{V,eq(ULS)}$	[mm]	5,19	6,72	5,37	9,27

Table C8: Displacements under **seismic loading**, performance category **C2**
without filling of annular gap, concrete screw BSZ zinc plated

Anchor size			BSZ 8	BSZ 10	BSZ 12	BSZ 14
Nominal embedment depth	h_{nom}	[mm]	65	85	100	115
Tension load						
Type with hexagon drive						
Displacement DLS	$\delta_{N,eq(DLS)}$	[mm]	0,66	0,32	0,57	1,16
Displacement ULS	$\delta_{N,eq(ULS)}$	[mm]	1,74	1,36	2,26	4,39
Type countersunk head						
Displacement DLS	$\delta_{N,eq(DLS)}$	[mm]	0,66	0,32	-	-
Displacement ULS	$\delta_{N,eq(ULS)}$	[mm]	1,74	1,36	-	-
Shear load						
Type hexagon drive and with clearance hole in the fixture						
Displacement DLS	$\delta_{V,eq(DLS)}$	[mm]	4,21	4,71	4,42	5,60
Displacement ULS	$\delta_{V,eq(ULS)}$	[mm]	7,13	8,83	6,95	12,63
Type countersunk head with clearance hole in the fixture						
Displacement DLS	$\delta_{V,eq(DLS)}$	[mm]	2,51	2,98	-	-
Displacement ULS	$\delta_{V,eq(ULS)}$	[mm]	7,76	6,25	-	-

Concrete Screw BSZ

Performance
Displacements under **seismic loading**, performance category **C2**

Annex C7