

## DECLARACIÓN DE PRESTACIONES

DoP no MKT-1.2-300\_es

- ✧ **Código de identificación única del producto tipo:** **MKT Anclaje de clavo N**
- ✧ **Usos previstos:** Anclaje de expansión controlado por fuerza para anclar uso múltiple para Aplicaciones no estructurales en hormigón, ver Anexo / Annex B
- ✧ **Fabricante:** MKT Metall-Kunststoff-Technik GmbH & Co.KG  
Auf dem Immel 2  
67685 Weilerbach
- Sistemas de evaluación y verificación de la constancia de las prestaciones (EVCP):** 2+
- ✧ **Documento de evaluación europeo:** **ETAG 001-6**  
valuación técnica europea: **ETA-11/0240, 07.05.2015**  
Organismo de evaluación técnica: DIBt, Berlin  
Organismos notificados: NB 2873 – Technische Universität Darmstadt

✧ **Prestaciones declaradas:**

Características esenciales	Prestaciones
<b>Resistencia mecánica y estabilidad (BWR 1)</b>	
Valores característicos	Anexo/Annex C1
<b>Seguridad en caso de incendio (BWR 2)</b>	
El comportamiento del fuego	Clase A1
Resistencia al fuego	Anexo/Annex C2

Las prestaciones del producto identificado anteriormente son conformes con el conjunto de prestaciones declaradas. La presente declaración de prestaciones se emite, de conformidad con el Reglamento (UE) no 305/2011, bajo la sola responsabilidad del fabricante arriba identificado.

Firmado por y en nombre del fabricante por:

  
**Stefan Weustenhagen**  
(Director general)  
Weilerbach, 01.01.2021

p.p.   
**Dipl.-Ing. Detlef Bigalke**  
(Director de Desarrollo de Productos)



El original de esta declaración de rendimiento fue escrito en alemán. En caso de desviaciones en la traducción, la versión alemana es.

## Specifications of intended use

### Anchorage subject to:

- static and quasi-static loads

### Base materials:

- reinforced or unreinforced normal weight concrete according to EN 206-1:2000
- strength classes C12/15 to C50/60 according to EN 206-1:2000
- cracked and non-cracked concrete

Use conditions (environmental conditions):	Effective anchorage depth
<ul style="list-style-type: none"> <li>• Structures subject to dry internal conditions; (zinc plated steel, stainless steel or high corrosion resistant steel).</li> </ul>	$h_{ef} \geq 30\text{mm}$ and $h_{ef,red} \geq 25\text{mm}$
<ul style="list-style-type: none"> <li>• Structures subject to permanently damp internal conditions, if no particular aggressive conditions exist; (stainless steel or high corrosion resistant steel).</li> </ul>	$h_{ef} \geq 30\text{mm}$ and $h_{ef,red} \geq 25\text{mm}$
<ul style="list-style-type: none"> <li>• Structures subject to external atmospheric exposure including industrial and marine environment, if no particular aggressive conditions exist; (stainless steel or high corrosion resistant steel).</li> </ul>	$h_{ef} \geq 30\text{mm}$
<ul style="list-style-type: none"> <li>• Structures subject to external atmospheric exposure and to permanently damp internal condition, if other particular aggressive conditions; (high corrosion resistant steel).</li> </ul>	$h_{ef} \geq 30\text{mm}$

Note: Particular aggressive conditions are e.g. permanent, alternating immersion in seawater or the splash zone of seawater, chloride atmosphere of indoor pools or atmosphere with extreme chemical pollution (e.g. in desulphurization plants or road tunnels where de-icing materials are used.)

### Design:

- Anchorages are designed under the responsibility of an engineer experienced in anchorages and concrete work.
- Verifiable calculation notes and drawings are prepared taking account of the loads to be anchored. The position of the anchor is indicated on the design drawings (e.g. position of the anchor relative to reinforcement or to supports, etc.).
- The design of the fixture is such that in case of excessive slip or failure of one anchor the load can be transmitted to neighbouring anchors.
- Anchorages under static or quasi-static actions for multiple use in non-structural applications are designed in accordance with:
  - ETAG 001, Annex C, Edition August 2010, design method C or
  - CEN/TS 1992-4: 2009, design method C
- Fasteners are only to be used for multiple use for non-structural application, according to ETAG 001 Part 6, Edition August 2010.
- Anchorages under fire exposure are designed in accordance with:
  - EOTA Technical Report TR 020, Edition May 2004 or
  - CEN/TS 1992-4: 2009, Annex D
  - It must be ensured that local spalling of the concrete cover does not occur.

### Installation:

- Anchor installation carried out by appropriately qualified personnel and under the supervision of the person responsible for technical matters of the site,
- Anchor installation in accordance with the manufacturer's specifications and drawings and using the appropriate tools,
- Hammer drilling only,
- Anchor installation such that the effective setting depth is complied with. This compliance is ensured, if the admissible thickness of fixture is kept or the loop of Nail Anchor N-O rests on the concrete surface.

## Nail Anchor N

Intended use  
Specifications

Annex B1

**Table B1: Installation parameters**

Anchor type			N 6 N-K N-O	N 8 N-M	N 6 N-K N-O	N 8 N-M
Effective anchorage depth	$h_{ef} \geq$	[mm]	25 <sup>1)</sup>		30	
Nominal drill hole diameter	$d_0$	[mm]	6	6	6	6
Cutting diameter of drill bit	$d_{cut} \leq$	[mm]	6,40	6,40	6,40	6,40
Depth of drill hole	$h_1 \geq$	[mm]	35	35	40	40
Diameter of clearance hole in the fixture	$d_f \leq$	[mm]	7	9	7	9
Maximum tightening torque (N 6 and N 8 only)	$T_{inst} \leq$	[Nm]	4	4	4	4
Minimum member thickness	$h_{min}$	[mm]	80	80	80	80

<sup>1)</sup> Internal use only

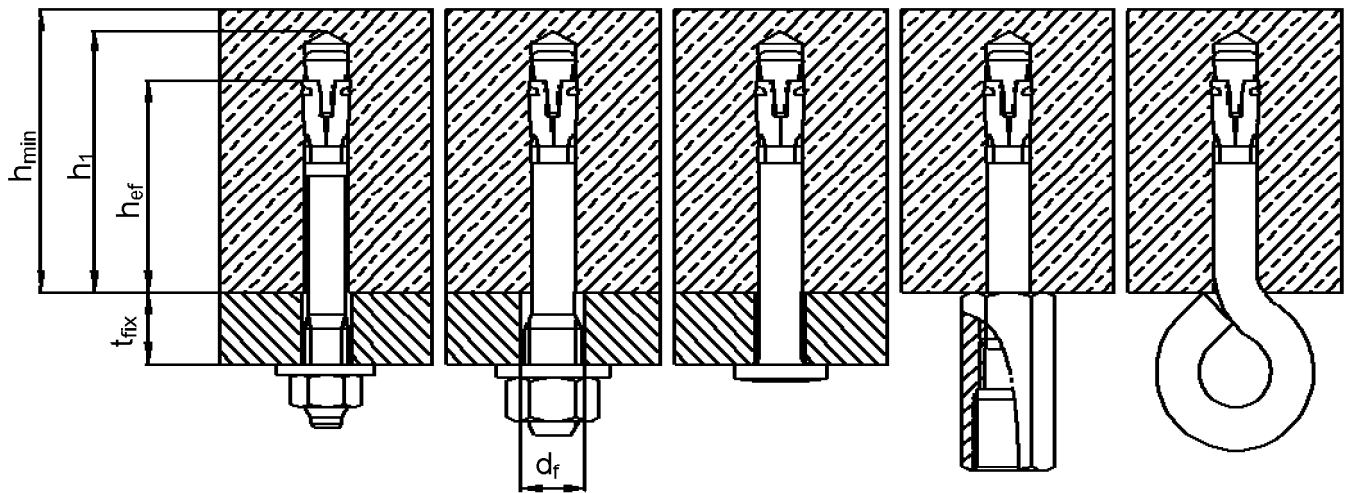

**Nail Anchor N**

**Intended use**  
Installation parameters

**Annex B2**

# Installation instructions

	N 6 / N 8	N-K	N-M	N-O
1				
	<b>Drill hole perpendicular to concrete surface.</b>			
2				
	<b>Blow out dust.</b>			
3		-		-
	<b>Check position of nut.</b>		<b>Check position of coupling nut.</b>	
4				
	<b>Drive in anchor.</b>			
5				
	<b>Max. tightening torque <math>T_{inst} \leq 4 \text{ Nm}</math> may be applied by using torque wrench.</b>		-	

## Nail Anchor N

**Intended use**  
Installation instructions

**Annex B3**

**Table C1:** Characteristic and design resistance for a **fixing point** <sup>1)</sup>, design method C

Anchor types		N 6	N 8 N-K N-M	N-O	N 6	N 8 N-K N-M	N-O
<b>Effective anchorage depth</b>	$h_{ef} \geq$ [mm]	25			30		
Partial safety factor for any direction	$\gamma_M$	1,5					
<b>Optimized for maximum load</b>							
Characteristic resistance <b>C12/15</b>	$F_{Rk}$ [kN]	3,0	3,0 <sup>4)</sup>	1,5	4,0	4,0 <sup>4)</sup>	1,5
Characteristic resistance <b>C20/25 to C50/60</b>		4,5	4,5 <sup>4)</sup>		5,9	5,9 <sup>4)</sup>	
Design resistance <b>C12/15</b>	$F_{Rd}$ [kN]	2,0	2,0 <sup>4)</sup>	1,0	2,7	2,7 <sup>4)</sup>	1,0
Design resistance <b>C20/25 to C50/60</b>		3,0	3,0 <sup>4)</sup>		3,9	3,9 <sup>4)</sup>	
Respective spacing between fixing points <sup>1) 2)</sup>	$\frac{S_{cr}}{\text{for } c_{cr} \geq}$ [mm]	100					
		200					
Respective edge distance <sup>2)</sup>	$\frac{C_{cr}}{\text{for } s_{cr} \geq}$ [mm]	100					
		200					
<b>Optimized for minimum edge distance</b>							
Characteristic resistance <b>C12/15</b>	$F_{Rk}$ [kN]	1,5	1,5 <sup>4)</sup>	1,5	2,0	2,0 <sup>4)</sup>	1,5
Characteristic resistance <b>C20/25 to C50/60</b>		2,0	2,0 <sup>4)</sup>		2,5	2,5 <sup>4)</sup>	
Design resistance <b>C12/15</b>	$F_{Rd}$ [kN]	1,0	1,0 <sup>4)</sup>	1,0	1,3	1,3 <sup>4)</sup>	1,0
Design resistance <b>C20/25 to C50/60</b>		1,3	1,3 <sup>4)</sup>		1,7	1,7 <sup>4)</sup>	
Respective spacing between fixing points <sup>1)</sup>	$\frac{C_{cr}}{\text{for } s_{cr} \geq}$ [mm]	50					
		100					
<b>Shear load with lever arm</b>							
Characteristic resistance, <b>steel zinc plated</b>	$M^0_{Rk,s}$ [Nm]	9,2	12,7	<sup>3)</sup>	9,2	12,7	<sup>3)</sup>
Characteristic resistance, <b>stainless steel A4/HCR</b>		9,2	13,5	<sup>3)</sup>	9,2	13,5	<sup>3)</sup>
Partial safety factor	$\gamma_{Ms}$	1,25					

1) A fixing point is defined as:

- Single anchor,
- Double anchor group with a minimum spacing  $s$  of  $50 \text{ mm} \leq s < s_{cr}$  or
- Quadruple anchor group with a minimum spacing  $s$  of  $50 \text{ mm} \leq s < s_{cr}$

If the spacing in a fixing point is greater than or equal to the respective spacing in this table, the characteristic resistances apply to every single anchor.

2) Intermediate values can be linearly interpolated.

3) Proof against failure due to shear load with lever arm is not required.

4) When applying a shear load to anchor version N-M, shear load with lever arm must be proven.

**Nail Anchor N**

**Performance**  
Characteristic and design resistance

**Annex C1**

**Table C2:** Characteristic resistance for a fixing point <sup>1)</sup> under **fire exposure** in concrete C20/25 to C50/60, design method C

Fire resistance class		N 6 N 8	N-K	N-M <sup>3)</sup>	N-O	N 6 N 8	N-K	N-M <sup>3)</sup>	N-O		
Effective anchorage depth	$h_{ef} \geq$	[mm]	25			30					
<b>Load in any direction</b>											
R 30	Characteristic resistance, <b>steel zinc plated</b>	$F_{Rk,fi}$	[kN]	0,6	0,6	0,6	0,2	0,9	0,9	0,8	-
R 60				0,6	0,6	0,6	0,2	0,7	0,8	0,7	-
R 90				0,5	0,6	0,6	0,1	0,5	0,6	0,6	-
R120				0,4	0,5	0,5	0,1	0,4	0,5	0,6	-
R 30	Characteristic resistance, <b>stainless steel A4 / HCR</b>	$F_{Rk,fi}$	[kN]	0,6	0,6	0,6	0,2	0,9	0,9	0,8	0,2
R 60				0,6	0,6	0,6	0,2	0,9	0,9	0,7	0,2
R 90				0,5	0,6	0,6	0,1	0,9	0,9	0,6	0,1
R120				0,4	0,5	0,5	0,1	0,7	0,7	0,6	0,1
R 30 – R 120	Edge distance	$C_{cr,fi}$	[mm]	50							
	Spacing	$S_{cr,fi}$	[mm]	100							
<b>Shear load with lever arm</b>											
R 30	Characteristic resistance, <b>steel zinc plated</b>	$M^0_{Rk,fi}$	[Nm]	0,7	1,0	0,7	<sup>2)</sup>	0,7	1,0	0,7	-
R 60				0,5	0,8	0,7	<sup>2)</sup>	0,5	0,8	0,7	-
R 90				0,4	0,5	0,6	<sup>2)</sup>	0,4	0,5	0,6	-
R120				0,3	0,4	0,5	<sup>2)</sup>	0,3	0,4	0,5	-
R 30	Characteristic resistance, <b>stainless steel A4 / HCR</b>	$M^0_{Rk,fi}$	[Nm]	1,4	2,1	0,7	<sup>2)</sup>	1,4	2,1	0,7	<sup>2)</sup>
R 60				1,1	1,5	0,7	<sup>2)</sup>	1,1	1,5	0,7	<sup>2)</sup>
R 90				0,7	1,0	0,6	<sup>2)</sup>	0,7	1,0	0,6	<sup>2)</sup>
R120				0,5	0,7	0,5	<sup>2)</sup>	0,5	0,7	0,5	<sup>2)</sup>
If the fire attack is from more than one side, the edge distance shall be $\geq 300$ mm.											

<sup>1)</sup> A fixing point is defined as:

- Single anchor,
- Double anchor group with a minimum spacing  $s$  of  $50 \text{ mm} \leq s < S_{cr,fi}$  or
- Quadruple anchor group with a minimum spacing  $s$  of  $50 \text{ mm} \leq s < S_{cr,fi}$

If the spacing in a fixing point is greater than or equal to the respective spacing in this table, the characteristic resistances apply to every single anchor.

<sup>2)</sup> Proof against failure due to shear load with lever arm is not required.

<sup>3)</sup> Only in connection with threaded rods M8, M10 or M12 minimum strength class 5.8. When applying shear load to this anchor version, shear load with lever arm must be proven.

## Nail Anchor N

**Performance**  
Characteristic resistance under fire exposure

**Annex C2**