

**DECLARAȚIA DE PERFORMANȚĂ**DoP Nr.: **MKT-1.1-600\_ro**

- ❖ **Cod unic de identificare al produsului-tip:** **Ancora de fixare sarcini grele SLZ**
- ❖ **Utilizare (utilizări) preconizată (preconizate):** Ancora mecanică (oțel zincat) în dimensiune 14 / M10 pentru ancorare în beton, a se vedea anexa / Annex B
- ❖ **Fabricant:** MKT Metall-Kunststoff-Technik GmbH & Co.KG  
Auf dem Immel 2  
67685 Weilerbach
- ❖ **Sistem sau sisteme de evaluare și verificare a constanței performanței:** 1
- ❖ **Documentul de evaluare european:** **EAD 330232-00-0601**  
Evaluarea tehnică europeană: **ETA-09/0342, 01.03.2018**  
Organismul de evaluare tehnică: **DIBt, Berlin**  
Organism (organisme) notificat(e): **NB 2873 – Technische Universität Darmstadt**
- ❖ **Performanța (performanțe) declarată (declarate):**

Caracteristici esențiale	Performanță
<b>Rezistență mecanică și stabilitate (BWR 1)</b>	
Rezistențe caracteristice (efecte statice și cvasistatice), Schimbări	Anexa / Annex C1 – C2
<b>Securitatea la incendiu (BWR 2)</b>	
Comportamentul la foc	Clasa A1
Rezistență la foc	Anexa / Annex C3

Performanța produsului de mai sus este performanța / performanța declarată. Producătorul de mai sus este singurul responsabil de întocmirea declarației de performanță în conformitate cu Regulamentul (EU) nr. 305/2011.

Semnată pentru și în numele fabricantului de către:



**Stefan Weustenhagen**  
(Director general)  
**Weilerbach, 01.01.2021**

p.p.   
**Dipl.-Ing. Detlef Bigalke**  
(Sef de dezvoltare a produselor)



Originalul acestei declarații de performanță a fost scris în limba germană. În cazul abaterilor în traducere, versiunea germană este validă.

## Specifications of intended use

### Anchorage subject to:

- Static or quasi-static action
- fire exposure

### Base materials:

- Reinforced or unreinforced normal weight concrete according to EN 206-1:2000
- Strength classes C20/25 to C50/60 according to EN 206-1:2000
- Cracked and uncracked concrete

### Use conditions (Environmental conditions):

- Structures subject to dry internal conditions (zinc plated steel).

### Design:

- Anchorages are designed under the responsibility of an engineer experienced in anchorages and concrete work.
- Verifiable calculation notes and drawings are prepared taking account of the loads to be anchored. The position of the anchor is indicated on the design drawings (e.g. position of the anchor relative to reinforcement or to supports, etc.).
- Anchorages are designed according to FprEN 1992-4: 2016 and TR 055.

### Installation:

- Anchor installation carried out by appropriately qualified personnel and under the supervision of the person responsible for technical matters of the site.
- Positioning of the drill holes without damaging the reinforcement
- In case of aborted hole: new drilling at a minimum distance away of twice the depth of the aborted hole or smaller distance if the aborted drill hole is filled with high strength mortar and if under shear or oblique tension load it is not in the direction of load application.
- Anchor installation such that the effective anchorage depth is complied with. This compliance is ensured, when the embedment mark of the anchor does no more exceed the concrete surface
- Drilling by hammer drill bit (use of vacuum drill bit is admissible)

## Highload Anchor SLZ

Intended use  
Specifications

Annex B1

## Installation instructions

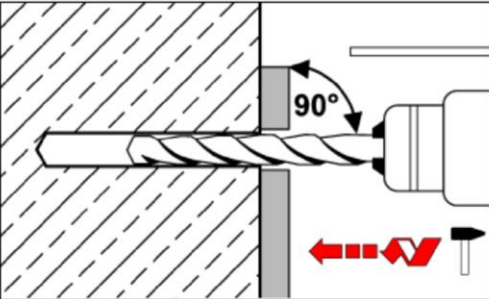
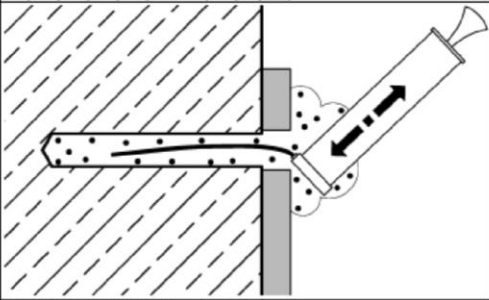
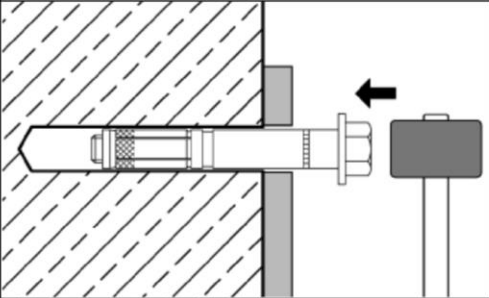
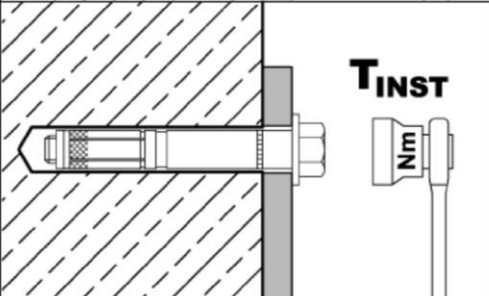
1		<p>Drill hole perpendicular to concrete surface. Using a vacuum drill bit, proceed with step 3.</p>
2		<p>Blow out dust. Alternatively vacuum clean down to the bottom of the hole.</p>
3		<p>Drive in anchor.</p>
4		<p>Apply tightening torque <math>T_{inst}</math> by using torque wrench.</p>

### Highload Anchor SLZ

Intended use  
Installation instructions

Annex B2

**Table B1: Installation parameters**

Anchor size			14/M10
Size of thread			M10
Effective anchorage depth	$h_{ef}$	[mm]	65
Nominal diameter of drill bit	$d_0$	[mm]	14
Cutting diameter of drill bit	$d_{cut} \leq$	[mm]	14,5
Depth of drill hole	$h_1 \geq$	[mm]	85
Diameter of clearance hole in the fixture mounted on distance sleeve	$d_f \leq$	[mm]	16
Diameter of clearance hole in the fixture mounted on threaded bolt	$d_f \leq$	[mm]	12
Installation torque	$T_{inst}$	[Nm]	50
Minimum thickness of member	$h_{min}$	[mm]	130
Minimum spacing	$s_{min}$	[mm]	60
	$c \geq$	[mm]	120
Minimum edge distance	$c_{min}$	[mm]	70
	$s \geq$	[mm]	130

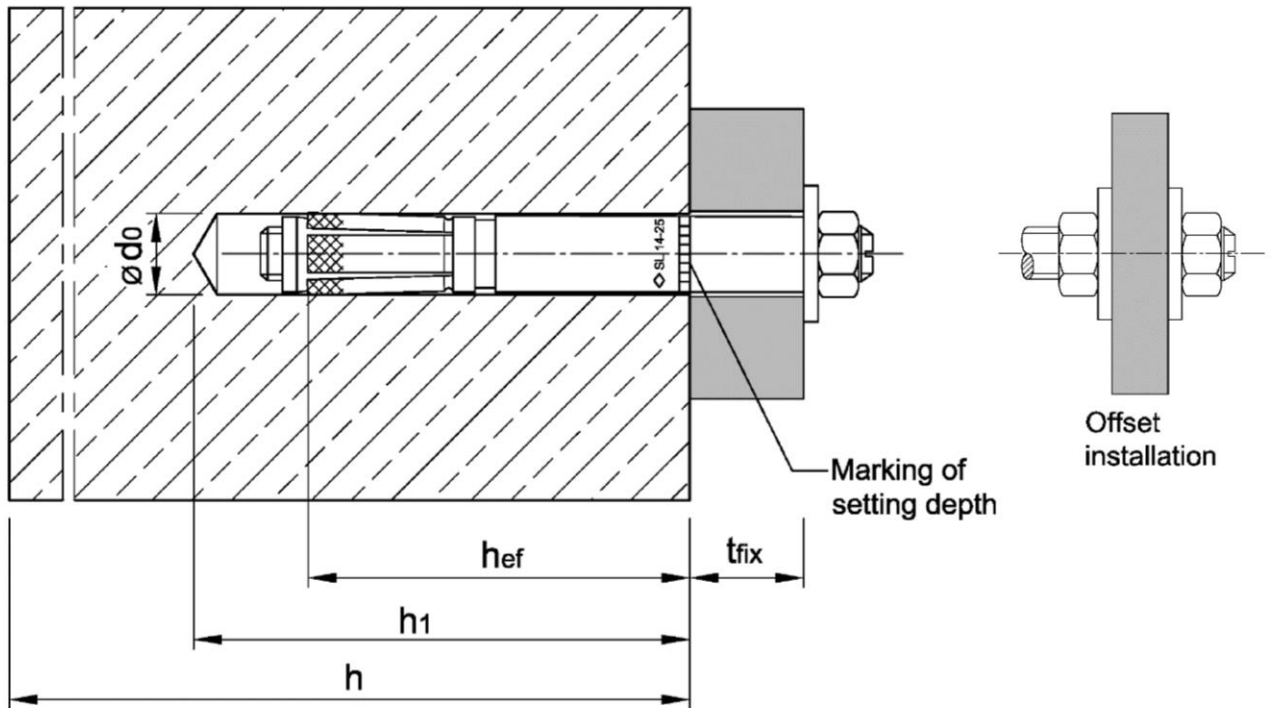

**Highload Anchor SLZ**

**Intended use**  
Installation parameters

**Annex B3**

**Table C1: Characteristic values for tension loads**

<b>Anchor size</b>			<b>14/M10</b>
Installation safety factor	$\gamma_{inst}$	[-]	1,0
<b>Steel failure</b>			
Characteristic resistance	$N_{RK,s}$	[kN]	46
Partial safety factor	$\gamma_{Ms}$	[-]	1,5
<b>Pull-out failure</b>			
Characteristic resistance in cracked concrete C20/25	$N_{RK,p}$	[kN]	12
Characteristic resistance in uncracked concrete C20/25	$N_{RK,p}$	[kN]	20
Increasing factors for $N_{RK,p}$	$\psi_C$	[-]	$\left(\frac{f_{ck}}{20}\right)^{0,5}$
<b>Concrete cone failure</b>			
Effective Anchorage depth	$h_{ef}$	[mm]	65
Spacing	$s_{cr,N}$	[mm]	3 $h_{ef}$
Edge distance	$c_{cr,N}$	[mm]	1,5 $h_{ef}$
Factor $k_1$ for cracked concrete	$k_{cr,N}$	[-]	7,7
Factor $k_1$ for uncracked concrete	$k_{ucr,N}$	[-]	11,0
<b>Splitting failure</b>			
Characteristic resistance in uncracked concrete	$N^0_{RK,sp}$	[kN]	min [ $N_{RK,p}; N^0_{RK,c}$ ]
Spacing	$s_{cr,sp}$	[mm]	390
Edge distance	$c_{cr,sp}$	[mm]	195

**Table C2: Displacements under tension loads**

<b>Anchor size</b>			<b>14/M10</b>
Tension load in cracked concrete	N	[kN]	5,7
Displacement	$\delta_{N0}$	[mm]	0,8
	$\delta_{N\infty}$	[mm]	1,5
Tension load in uncracked concrete	N	[kN]	9,5
Displacement	$\delta_{N0}$	[mm]	0,3
	$\delta_{N\infty}$	[mm]	1,2

**Highload Anchor SLZ**

**Performance**  
 Characteristic values and displacements under **tension load**

**Annex C1**

**Table C3: Characteristic values for shear loads**

<b>Anchor size</b>			<b>14/M10</b>
<b>Steel failure without lever arm</b>			
Characteristic resistance, fixture mounted on distance sleeve with $t_{fix} \leq 75$ mm	$V^0_{RK,s}$	[kN]	32,8
Characteristic resistance, fixture mounted on distance sleeve with $t_{fix} > 75$ mm	$V^0_{RK,s}$	[kN]	23,2
Factor	$k_7$	[-]	1,0
Partial safety factor	$\gamma_{Ms}$	[-]	1,25
<b>Steel failure with lever arm</b>			
Characteristic resistance	$M^0_{RK,s}$	[Nm]	60
Partial safety factor	$\gamma_{Ms}$	[-]	1,25
<b>Concrete pry-out failure</b>			
Factor	$k_8$	[-]	2,0
<b>Concrete edge failure</b>			
Effective length of anchor in shear loading	$l_f$	[mm]	65
Outside diameter of anchor	$d_{nom}$	[mm]	14

**Table C4: Displacements under shear loads**

<b>Anchor size</b>			<b>14/M10</b>
Shear load in non-cracked concrete	$V$	[kN]	13,2
Displacement	$\delta_{V0}$	[mm]	2,2
	$\delta_{V\infty}$	[mm]	3,3

**Highload Anchor SLZ**

**Performance**  
 Characteristic values and displacements under **shear load**

**Annex C2**

**Table C5: Characteristic values under fire exposure in concrete C20/25 to C50/60**

<b>Anchor size</b>			<b>14/M10</b>	
<b>Tension load</b>				
<b>Steel failure</b>				
Characteristic resistance	R30	$N_{Rk,s,fi}$	[kN]	0,9
	R60			0,8
	R90			0,6
	R120			0,5
<b>Shear load</b>				
<b>Steel failure without lever arm</b>				
Characteristic resistance	R30	$V_{Rk,s,fi}$	[kN]	0,9
	R60			0,8
	R90			0,6
	R120			0,5
<b>Steel failure with lever arm</b>				
Characteristic resistance	R30	$M^0_{Rk,s,fi}$	[Nm]	1,1
	R60			1,0
	R90			0,7
	R120			0,6

**Highload Anchor SLZ**

**Performance**  
Characteristic values under **fire exposure**

**Annex C3**