



...eine starke Verbindung

PROHLÁŠENÍ O VLASTNOSTECH

DoP č. MKT-261 - cz

- ✧ **Jedinečný identifikační kód typu výrobku:** Těžká kotva SL
- ✧ **Zamýšlené/zamýšlená použití:** Výkonná kotva pro roztažení z pozinkované oceli o rozměru M10 pro ukotvení v nepoškrábaném betonu, viz příloha / Annex B
- ✧ **Výrobce:** MKT Metall-Kunststoff-Technik GmbH & Co.KG
Auf dem Immel 2
67685 Weilerbach
- ✧ **System/systémy POSV:** 1
- ✧ **Evropský dokument pro posuzování:** EAD 330232-00-0601
Evropské technické posouzení: ETA-08/0230, 14.05.2018
Subjekt pro technické posuzování: DIBt, Berlin
Oznámený subjekt/oznámené subjekty: NB 1343 – MPA, Darmstadt

✧ **Deklarovaná vlastnost / Deklarované vlastnosti:**

Základní charakteristiky	Vlastnosti
Mechanická odolnost a stabilita (BWR1)	
Charakteristické odpory pro statické a kvazistatické zatížení, Posuny	Příloha/Annex C1 – C2
Charakteristické odolnosti pro seismické výkonnostní kategorie C1 + C2, Posuny	NPD (No Performance Determined) žádná vlastnost není stanovena
Požární bezpečnost (BWR2)	
Chování při požáru	Třída A1
Požární odolnost	NPD (No Performance Determined) žádná vlastnost není stanovena

Vlastnosti výše uvedeného výrobku jsou ve shodě se souborem deklarovaných vlastností. Toto prohlášení o vlastnostech se v souladu s nařízením (EU) č. 305/2011 vydává na výhradní odpovědnost výrobce uvedeného výše.

Podepsáno za výrobce a jeho jménem:

Stefan Weustenhagen

(Výkonný ředitel)
Weilerbach, 14.05.2018

p.p. 
Dipl.-Ing. Detlef Bigalke
(Vedoucí vývoje produktu)



Originál tohoto prohlášení byl napsán v němčině. V případě odchylek v překladu platí německá verze.

Specifications of intended use

Anchorage subject to:

- Static or quasi-static action

Base materials:

- Reinforced or unreinforced normal weight concrete without fibres of strength classes C20/25 to C50/60 according to EN 206:2013
- Uncracked concrete

Use conditions (Environmental conditions):

- Structures subject to dry internal conditions (zinc plated steel).

Design:

- Anchorages are designed under the responsibility of an engineer experienced in anchorages and concrete work.
- Verifiable calculation notes and drawings are prepared taking account of the loads to be anchored. The position of the anchor is indicated on the design drawings (e.g. position of the anchor relative to reinforcement or to supports, etc.).
- Anchorages are designed according to FprEN 1992-4: 2016 and EOTA Technical Report TR 055.

Installation:

- Anchor installation carried out by appropriately qualified personnel and under the supervision of the person responsible for technical matters of the site.
- Positioning of the drill holes without damaging the reinforcement
- In case of aborted hole: new drilling at a minimum distance away of twice the depth of the aborted hole or smaller distance if the aborted drill hole is filled with high strength mortar and if under shear or oblique tension load it is not in the direction of load application.
- Anchor installation such that the effective anchorage depth is complied with. This compliance is ensured, when the embedment mark of the anchor does no more exceed the concrete surface
- Drilling by hammer drill bit (use of vacuum drill bit is admissible)

Highload Anchor SL

Intended use
Specifications

Annex B1

Installation instructions

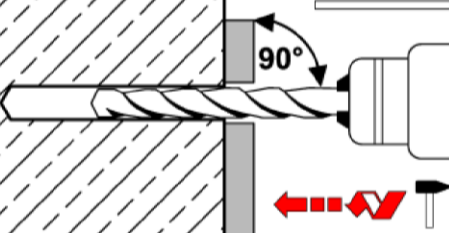
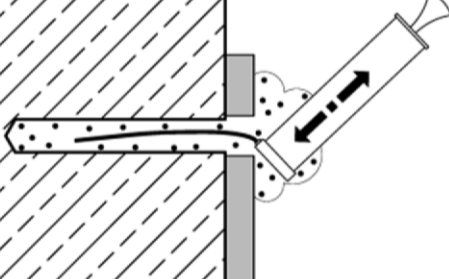
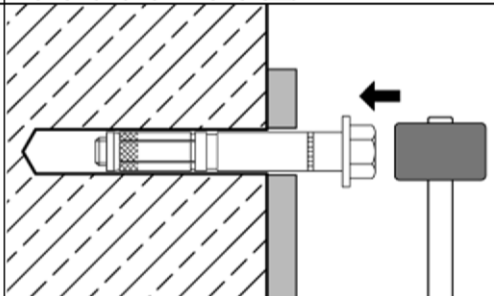
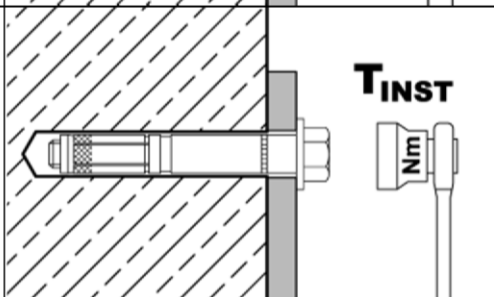
1		<p>Drill hole perpendicular to concrete surface. Using a vacuum drill bit, proceed with step 3.</p>
2		<p>Blow out dust. Alternatively vacuum clean down to the bottom of the hole.</p>
3		<p>Drive in anchor.</p>
4		<p>Apply tightening torque T_{inst} by using torque wrench.</p>

Highload Anchor SL

Intended use
Installation instructions

Annex B2

Table B1: Installation parameters

Anchor size			14/M10
Size of thread			M10
Effective anchorage depth	h_{ef}	[mm]	65
Nominal diameter of drill bit	d_0	[mm]	14
Cutting diameter of drill bit	$d_{cut} \leq$	[mm]	14,5
Depth of drill hole	$h_1 \geq$	[mm]	85
Diameter of clearance hole in the fixture mounted on distance sleeve	$d_f \leq$	[mm]	16
Diameter of clearance hole in the fixture mounted on threaded bolt	$d_f \leq$	[mm]	12
Installation torque	T_{inst}	[Nm]	50
Minimum thickness of member	h_{min}	[mm]	130
Minimum spacing	s_{min}	[mm]	60
Minimum edge distance	c_{min}	[mm]	120

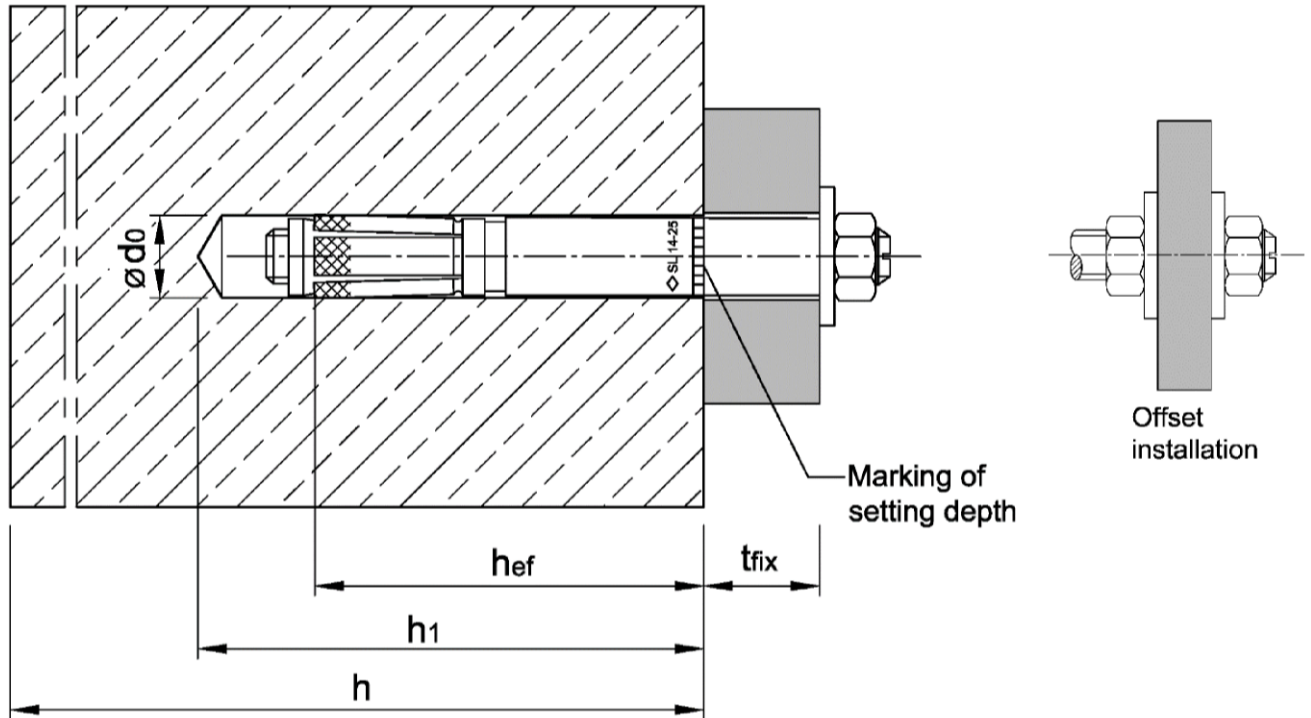

Highload Anchor SL

Intended use
Installation parameters

Annex B3

Table C1: Characteristic values for tension loads

Anchor size			14/M10
Installation factor	γ_{inst}	[-]	1,0
Steel failure			
Characteristic resistance	$N_{Rk,s}$	[kN]	46
Partial factor	γ_{Ms}	[-]	1,5
Pull-out failure			
Characteristic resistance in uncracked concrete C20/25	$N_{Rk,p}$	[kN]	20
Increasing factor for $N_{Rk,p}$	ψ_C	[-]	$\left(\frac{f_{ck}}{20}\right)^{0,5}$
Concrete cone failure			
Effective Anchorage depth	h_{ef}	[mm]	65
Spacing	$s_{cr,N}$	[mm]	3 h_{ef}
Edge distance	$c_{cr,N}$	[mm]	1,5 h_{ef}
Factor k_1	$k_{ucr,N}$	[-]	11,0
Splitting failure			
Characteristic resistance in uncracked concrete	$N^0_{Rk,sp}$	[kN]	min [$N_{Rk,p}; N^0_{Rk,c}$]
Spacing	$s_{cr,sp}$	[mm]	6 h_{ef}
Edge distance	$c_{cr,sp}$	[mm]	3 h_{ef}

Table C2: Displacements under tension loads

Anchor size			14/M10
Tension load in uncracked concrete	N	[kN]	9,5
Displacement	δ_{N0}	[mm]	0,3
	$\delta_{N\infty}$	[mm]	0,6

Highload Anchor SL

Performance
Characteristic values and displacements under **tension load**

Annex C1

Table C3: Characteristic values for shear loads

Anchor size			14/M10
Steel failure without lever arm			
Characteristic resistance, fixture mounted on distance sleeve with $t_{fix} \leq 75$ mm	$V^0_{Rk,s}$	[kN]	32,8
Characteristic resistance, fixture mounted on distance sleeve with $t_{fix} > 75$ mm	$V^0_{Rk,s}$	[kN]	23,2
Factor	k_7	[-]	1,0
Partial factor	γ_{Ms}	[-]	1,25
Steel failure with lever arm			
Characteristic resistance	$M^0_{Rk,s}$	[Nm]	60
Partial factor	γ_{Ms}	[-]	1,25
Concrete pry-out failure			
Factor	k_8	[-]	2,0
Concrete edge failure			
Effective length of anchor in shear loading	l_f	[mm]	65
Outside diameter of anchor	d_{nom}	[mm]	14

Table C4: Displacements under shear loads

Anchor size			14/M10
Shear load in uncracked concrete	V	[kN]	13,2
Displacement	δ_{v0}	[mm]	2,2
	$\delta_{v\infty}$	[mm]	3,3

Highload Anchor SL

Performance
 Characteristic values and displacements under **shear load**

Annex C2